

# X2.5 G2



> Specification sheet



Our energy working for you.™

## Description

The X2.5 has all the strength and reliability the industry has come to expect from Cummins Inc., but in a smaller, lighter and more economical package. The X2.5 features direct fuel injection, resulting in cleaner quieter and more fuel efficient performance. The CoolPac system offers a cost effective, fully warranted, high ambient, integrated system solution capable of meeting our customer's application requirements.



This engine has been built to comply with CE certification.



This engine has been designed in facilities certified to ISO9001 and manufactured in facilities certified to ISO9001 or ISO9002.

## Features

The X2.5 is built to last, with a cast-iron block designed for durability and reliability. Design elements include:

- Bosch direct injection in-line pump for cleaner, more efficient fuel consumption.
- Parent bore block with deep, stiff crankcase and optimised rib arrangement to enhance strength and reduce noise.
- 12 volt electrical package as standard, with starter, alternator and fuel solenoid.
- Single spin-on oil filter and Fuel Filter
- SAE 3/11.5 flywheel housing

**Integrated Design** - CoolPac products are supplied complete and factory fitted with cooling package and air cleaner for a complete power package. Each component has been specifically developed and rigorously tested for G-Drive products, ensuring high performance, durability and reliability.

**Service and Support** - G-Drive products are backed by an uncompromising level of technical support and after sales service, delivered through a world class service network.

## 1500 rpm (50 Hz Ratings)

Gross Engine Output			Net Engine Output			Typical Generator Set Output					
Standby	Prime	Base	Standby	Prime	Base	Standby (ESP)		Prime (PRP)		Base (COP)	
kWm/BHP			kWm/BHP			kWe	kVA	kWe	kVA	kWe	kVA
27/36.3	24.37/32.67	18.96/25.41	26/35	23/31	21/28	22	27.5	20	25	18	22

Our energy working for you.™

[www.cumminsgdrive.com](http://www.cumminsgdrive.com)

©2012 | Cummins G-Drive Engines | Specifications Subject to Change Without Notice | Cummins is a registered trademark of Cummins Inc. (10/12) (GDSS173)

**BAV**  
Science and Industry Group  
[www.bav-co.com](http://www.bav-co.com)  
+98 (21) 22407575



## General Engine Data

Type	4- cycle, In-line, 3- cylinder, Naturally Aspirated, Diesel,
Bore mm	91.4mm (3.59 in.)
Stroke mm	127mm (5 in.)
Displacement	2.5 litre (153in. <sup>3</sup> )
Cylinder Block	Cast iron, 3 cylinder
Battery Charging Alternator	36 amps
Starting Voltage	12 volt, negative ground
Fuel System	Direct injection
Fuel Filter	Spin on fuel filters with Water Drain Facility
Lube Oil Filter Type(s)	Spin on full flow filter
Lube Oil Capacity (liters)	6.5
Flywheel Dimensions	3/11.5

## Coolpac Performance Data

Cooling System Design	Jacket Water cooled
Coolant Ratio	50% ethylene glycol; 50% water
Coolant Capacity (liters)	5.5
Limiting Ambient Temp.**	50degC
Fan Power kw	0.9
Cooling System Air Flow (m <sup>3</sup> /s)**	1.6
Air Cleaner Type	Heavy Duty Dry replaceable element with restriction indicator

\*\* @ 13 mm H<sub>2</sub>O Prime power

## Ratings Definitions

### Emergency Standby Power (ESP):

Applicable for supplying power to varying electrical load for the duration of power interruption of a reliable utility source. Emergency Standby Power (ESP) is in accordance with ISO 8528. Fuel Stop power in accordance with ISO 3046, AS 2789, DIN 6271 and BS 5514.

### Limited-Time Running Power (LTP):

Applicable for supplying power to a constant electrical load for limited hours. Limited-Time Running Power (LTP) is in accordance with ISO 8528.

### Prime Power (PRP):

Applicable for supplying power to varying electrical load for unlimited hours. Prime Power (PRP) is in accordance with ISO 8528. Ten percent overload capability is available in accordance with ISO 3046, AS 2789, DIN 6271 and BS 5514.

### Base Load (Continuous) Power (COP):

Applicable for supplying power continuously to a constant electrical load for unlimited hours. Continuous Power (COP) in accordance with ISO 8528, ISO 3046, AS 2789, DIN6271 and BS 5514.

## Weight & Dimensions

	Length	Width	Height	Weight (dry)
	mm	mm	mm	kg
CoolPac	1004	675	803	283
Shipping	1125	780	1000	350

## Fuel Consumption 1500 (50 Hz)

%	kWm	BHP	L/ph	US gal/ph
<b>Standby Power</b>				
100	27	36.3	6.5	1.7
<b>Prime Power</b>				
100	24.37	32.67	6.0	1.6
75	18.28	24.50	4.8	1.3
50	12.19	16.34	3.5	0.7
25	6.10	8.17	2.5	0.4
<b>Continuous Power</b>				
100	18.96	25.41	4.9	1.3

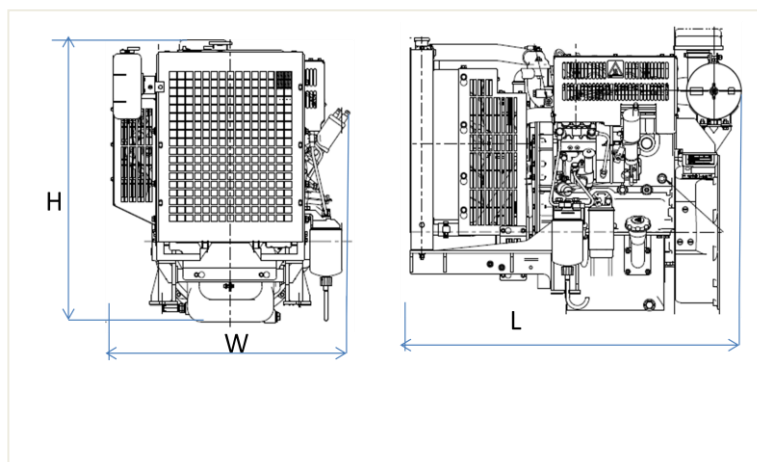

## Cummins G-Drive Engines

### Asia Pacific

10 Toh Guan Road  
#07-01  
TT International Tradepark  
Singapore 608838  
Phone 65 6417 2388  
Fax 65 6417 2399

### Europe, CIS, Middle East and Africa

Manston Park Columbus Ave  
Manston Ramsgate  
Kent CT12 5BF. UK  
Phone 44 1843 255000  
Fax 44 1843 255902

### Latin America

Rua Jati, 310, Cumbica  
Guarulhos, SP 07180-900  
Brazil  
Phone 55 11 2186 4552  
Fax 55 11 2186 4729

### Mexico

Cummins S. de R.L. de C.V.  
Eje 122 No. 200 Zona Industrial  
San Luis Potosí, S.L.P. 78090  
Mexico  
Phone 52 444 870 6700  
Fax 52 444 870 6811

### North America

1400 73rd Avenue N.E.  
Minneapolis, MN 55432  
USA  
Phone 1 763 574 5000  
USA Toll-free 1 877 769 7669  
Fax 1 763 574 5298

Our energy working for you.™

[www.cumminsgdrive.com](http://www.cumminsgdrive.com)

©2012 | Cummins G-Drive Engines | Specifications Subject to Change Without Notice | Cummins is a registered trademark of Cummins Inc. (10/12) (GDSS173)

**BAV**  
Science and Industry Group  
[www.bav-co.com](http://www.bav-co.com)  
+98 (21) 22407575

