

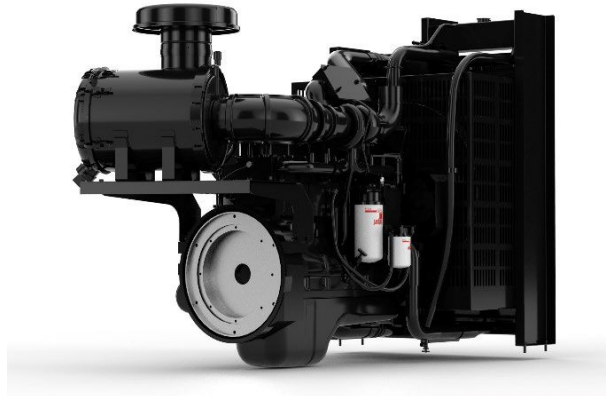

QSL9-G2

EU Stage IIIA / EPA Tier 3



Description

Cummins QSL engines are built to deliver heavy-duty performance in every piece of machinery. Full-authority electronic engine controls combine with the high-pressure fuel system, 24-valve design and centred injectors for one of the highest power-to-weight ratios in its class, with up to 50% torque rise. At the same time, the QSL delivers better fuel economy, has better cold starting capability and is up to 50% quieter in operation than predecessors.

Features

Common Rail Fuel System and Controls - Bosch high pressure common rail (HPCR) - Optimize engine performance to provide seamless integration and advanced diagnostics and programming options.

Holset HX40 Wastegated Turbo - Wastegated design optimizes transient response.

Integrated Block Design - Integrated fluid circuits replace hoses and eliminate potential leaks.

24-Valve Cylinder Head – Four valves per cylinder for increased power with faster response and fuel economy.

Coolpac Integrated Design - Products are supplied complete with cooling package and air cleaner kit for a complete power package. Each component has been specifically developed and rigorously tested for G-Drive products, ensuring high performance, durability and reliability.

Service and Support - G-Drive products are backed by an uncompromising level of technical support and after sales service, delivered through a world class service network.



This engine has been designed in facilities certified to ISO9001 and manufactured in facilities certified to ISO9001 or ISO9002.

This equipment has been designed and tested to meet EU product safety regulations. Material compliance declaration is available upon request

1500 rpm (50 Hz Ratings)

Gross engine output			Net engine output			Typical generator set output					
Standby	Prime	Base	Standby	Prime	Base	Standby (ESP)		Prime (PRP)		Base (COP)	
kWm/BHP			kWm/BHP			kWe	kVA	kWe	kVA	kWe	kVA
239/320	206/276	186/249	226/303	196/262	176/236	208	260	180	225	162	202

1800 rpm (60 Hz Ratings)

Gross engine output			Net engine output			Typical generator set output					
Standby	Prime	Base	Standby	Prime	Base	Standby (ESP)		Prime (PRP)		Base (COP)	
kWm/BHP			kWm/BHP			kWe	kVA	kWe	kVA	kWe	kVA
280/375	241/324	177/238	261/350	225/301	161/216	245	306	211	264	151	189

General Engine Data

Fuel Rating	FR96536
Type	4 cycle, in-line, Turbo Charged, Air-cooled
Bore mm	114 mm (4.5 in.)
Stroke mm	145 mm (5.7 in.)
Displacement litre	8.8 litre (543 in. ³)
Cylinder block	6 cylinder
Battery charging alternator	70 amps
Starting voltage	24-volt
Fuel system	Direct injection
Fuel filter	Spin-on fuel filters with water separator
Lube oil filter type(s)	Spin-on full flow filter
Lube oil capacity (l)	26.5
Flywheel dimensions	SAE1/14

Coolpac Performance Data

Cooling system design	Air-air Charge Cooled
Coolant ratio	50% ethylene glycol; 50% water
Coolant capacity (l)	15.0
Limiting ambient temp.** (°C)	55.0
Fan power (kWm)	7.5
Cooling system air flow (m ³ /s)**	9.4
Air cleaner type	Light Duty Dry replaceable element with restriction indicator

** @ 13mm H2O

Fuel Consumption 1500 (50 Hz)

%	kWm	BHP	L/hr	US Gal/hr
Standby Power				
100	239	320	62	16.3
Prime Power				
100	206	276	56	14.7
75	155	207	46	12.1
50	103	138	31	8.2
25	52	69	17	4.5
Continuous Power				
100	186	249	50	13.3

Fuel Consumption 1800 (60Hz)

%	kWm	BHP	L/hr	US Gal/hr
Standby Power				
100	280	375	73	19.3
Prime Power				
100	241	324	67	17.6
75	181	243	54	14.3
50	121	162	38	10.0
25	60	81	20	5.4
Continuous Power				
100	177	238	53	14.1

Our energy working for you.™

©2021 Cummins Inc. | QSL9-G2 (06/21)

BAV
Science and Industry Group
www.bav-co.com
+98 (21) 22407575

cummins.com

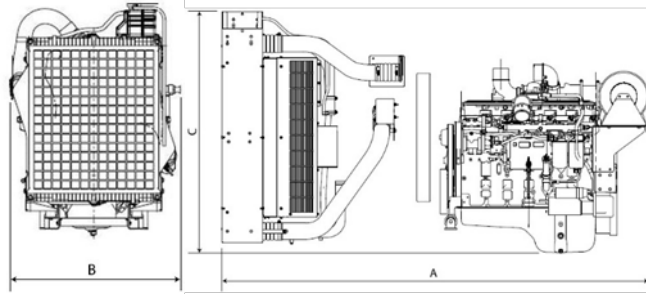

*Drawing for illustration purposes only.

Weights and Dimensions

Length mm	Width mm	Height mm	Weight (dry) kg
1624	1064	1463	910

Ratings Definitions

Emergency Standby Power (ESP):	Limited-Time Running Power (LTP):	Prime Power (PRP):	Base Load (Continuous) Power (COP):
Applicable for supplying power to varying electrical load for the duration of power interruption of a reliable utility source. Emergency Standby Power (ESP) is in accordance with ISO 8528. Fuel Stop power in accordance with ISO 3046, AS 2789, DIN 6271 and BS 5514.	Applicable for supplying power to a constant electrical load for limited hours. Limited-Time Running Power (LTP) is in accordance with ISO 8528.	Applicable for supplying power to varying electrical load for unlimited hours. Prime Power (PRP) is in accordance with ISO 8528. Ten percent overload capability is available in accordance with ISO 3046, AS 2789, DIN 6271 and BS 5514.	Applicable for supplying power continuously to a constant electrical load for unlimited hours. Continuous Power (COP) in accordance with ISO 8528, ISO 3046, AS 2789, DIN6271 and BS 5514.

For more information contact your local Cummins distributor or visit power.cummins.com

Our energy working for you.™

BAV
Science and Industry Group
www.bav-co.com
+98 (21) 22407575

