

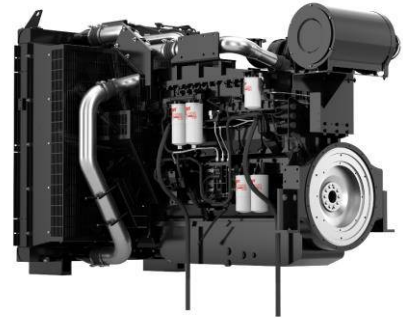

# QSK23-G5

EPA Tier 2



## Description

The QSK23 is an in-line 6-cylinder engine with a 23-litre displacement. This Quantum series utilizes sophisticated electronics and premium engineering to provide outstanding performance levels, reliability, and versatility for Standby, Prime and Continuous Power applications.



This engine has been designed in facilities certified to ISO9001 and manufactured in facilities certified to ISO9001 or ISO9002.

This equipment has been designed and tested to meet EU product safety regulations. Material compliance declaration is available upon request

## Features

**The QSK23 uses the Cummins High Pressure Injection (HPI) PT full authority electronic fuel system.** Featuring a high pressure (HPI-PT) full authority fuel system, that has exceptional fuel efficiency. The CM2250 ECM provides the Power Generation Interface (PGI), the widely accepted SAE J1939 industry standard CAN based communication network and advanced engine protection, ensuring faster connectivity along with a superior fault-finding capability.

**CTT (Cummins Turbo Technologies) HX82 turbocharging** utilizes exhaust energy with greater efficiency for improved emissions and fuel consumption.

**Charge Air Cooling** - QSK23 engine requires the use of an Air-to-Air heat exchanger or Charge-Air-Cooler (CAC) to reduce intake manifold temperature and to meet the lower emissions requirements.

**CoolPac Integrated Design** - Products are supplied complete with cooling package and air cleaner kit for a complete power package. Each component has been specifically developed and rigorously tested for G-Drive products, ensuring high performance, durability, and reliability.

**Service and Support** - G-Drive products are backed by an uncompromising level of technical support and after sales service, delivered through a world class service network.

## 1500 rpm (50 Hz Ratings)

Gross engine output			Net engine output			Typical generator set output					
Standby	Prime	Base	Standby	Prime	Base	Standby (ESP)		Prime (PRP)		Base (COP)	
kWm/BHP			kWm/BHP			kWe	kVA	kWe	kVA	kWe	kVA
665/891	582/780	433/580	641/859	565/757	416/557	603	753	531	663	391	488

## 1800 rpm (60 Hz Ratings)

Gross engine output			Net engine output			Typical generator set output					
Standby	Prime	Base	Standby	Prime	Base	Standby (ESP)		Prime (PRP)		Base (COP)	
kWm/BHP			kWm/BHP			kWe	kVA	kWe	kVA	kWe	kVA
746/1000	656/880	595/798	713/956	630/844	569/763	670	838	592	740	535	669

## General Engine Data

Fuel Rating	FR5341
Type	4 cycle, turbocharged
Bore mm	170
Stroke mm	170
Displacement litre	23.2
Cylinder block	6 cylinder
Battery charging alternator	35 amps
Starting voltage	24-volt
Fuel system	Cummins direct injection HPI
Fuel filter	Spin-on fuel filters with water separator
Lube oil filter type(s)	Spin-on full flow filter
Lube oil capacity (l)	103
Flywheel dimensions	SAE 0

## Coolpac Performance Data

Cooling system design	Air-air charge cooled
Coolant ratio	50% ethylene glycol; 50% water
Coolant capacity (l)	110
Limiting ambient temp.** (°C)	50.9 (50Hz); 55.0 (60Hz)
Fan power (kWm)	14.4 (50Hz); 24.3 (60Hz)
Cooling system air flow (m³/s)**	13.5 (50Hz); 16.6 (60Hz)
Air cleaner type	Dry replaceable element with restriction indicator

\*\* @ 13 mm H<sub>2</sub>O

## Fuel Consumption 1500 (50 Hz)

%	kWm	BHP	L/hr	US Gal./hr
<b>Standby Power</b>				
100	665	891	154	40.6
<b>Prime Power</b>				
100	582	780	134	35.3
75	436	585	105	27.8
50	291	390	74	19.6
25	145	195	42	11.1
<b>Continuous Power</b>				
100	433	580	105	27.6

## Fuel Consumption 1800 (60 Hz)

%	kWm	BHP	L/hr	US Gal./hr
<b>Standby Power</b>				
100	746	1000	182	48.0
<b>Prime Power</b>				
100	656	880	160	42.2
75	492	660	123	32.5
50	328	440	89	23.4
25	164	220	53	14.0
<b>Continuous Power</b>				
100	595	798	147	38.7

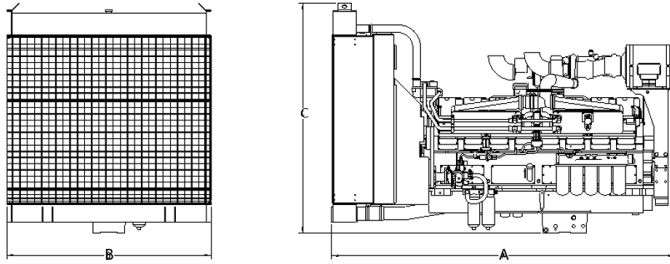

\*Drawing for illustration purposes only.

## Weights and Dimensions

Length mm	Width mm	Height mm	Weight (dry) kg
2976	1656	1964	3245

## Ratings Definitions

Emergency Standby Power (ESP):	Limited-Time Running Power (LTP):	Prime Power (PRP):	Base Load (Continuous) Power (COP):
Applicable for supplying power to varying electrical load for the duration of power interruption of a reliable utility source. Emergency Standby Power (ESP) is in accordance with ISO 8528. Fuel Stop power in accordance with ISO 3046, AS 2789, DIN 6271 and BS 5514.	Applicable for supplying power to a constant electrical load for limited hours. Limited-Time Running Power (LTP) is in accordance with ISO 8528.	Applicable for supplying power to varying electrical load for unlimited hours. Prime Power (PRP) is in accordance with ISO 8528. Ten percent overload capability is available in accordance with ISO 3046, AS 2789, DIN 6271 and BS 5514.	Applicable for supplying power continuously to a constant electrical load for unlimited hours. Continuous Power (COP) in accordance with ISO 8528, ISO 3046, AS 2789, DIN6271 and BS 5514.

For more information contact your local Cummins distributor or visit [power.cummins.com](http://power.cummins.com)

**Our energy working for you.™**

**BAV**  
Science and Industry Group  
[www.bav-co.com](http://www.bav-co.com)  
+98 (21) 22407575

