

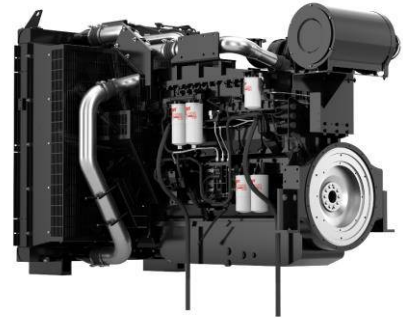

QSK23-G3

Fuel Optimized



Description

The QSK23 is an in-line 6-cylinder engine with a 23-litre displacement. This Quantum series utilizes sophisticated electronics and premium engineering to provide outstanding performance levels, reliability, and versatility for Standby, Prime and Continuous Power applications.



This engine has been designed in facilities certified to ISO9001 and manufactured in facilities certified to ISO9001 or ISO9002.

This equipment has been designed and tested to meet EU product safety regulations. Material compliance declaration is available upon request

Features

The QSK23 uses the Cummins High Pressure Injection (HPI) PT full authority electronic fuel system. Featuring a high pressure (HPI-PT) full authority fuel system, that has exceptional fuel efficiency. The CM2250 ECM provides the Power Generation Interface (PGI), the widely accepted SAE J1939 industry standard CAN based communication network and advanced engine protection, ensuring faster connectivity along with a superior fault-finding capability.

CTT (Cummins Turbo Technologies) HX82 turbocharging utilizes exhaust energy with greater efficiency for improved emissions and fuel consumption.

Charge Air Cooling - QSK23 engine requires the use of an Air-to-Air heat exchanger or Charge-Air-Cooler (CAC) to reduce intake manifold temperature and to meet the lower emissions requirements.

CoolPac Integrated Design - Products are supplied complete with cooling package and air cleaner kit for a complete power package. Each component has been specifically developed and rigorously tested for G-Drive products, ensuring high performance, durability, and reliability.

Service and Support - G-Drive products are backed by an uncompromising level of technical support and after sales service, delivered through a world class service network.

1500 rpm (50 Hz Ratings)

Gross engine output			Net engine output			Typical generator set output					
Standby	Prime	Base	Standby	Prime	Base	Standby (ESP)		Prime (PRP)		Base (COP)	
kWm/BHP			kWm/BHP			kWe	kVA	kWe	kVA	kWe	kVA
768/1030	701/940	537/720	743/996	684/917	520/697	720	900	663	829	505	631

1800 rpm (60 Hz Ratings)

Gross engine output			Net engine output			Typical generator set output					
Standby	Prime	Base	Standby	Prime	Base	Standby (ESP)		Prime (PRP)		Base (COP)	
kWm/BHP			kWm/BHP			kWe	kVA	kWe	kVA	kWe	kVA
895/1200	809/1085	653/875	860/1153	783/1050	627/840	808	1010	736	920	589	736

General Engine Data

Fuel Rating	FR5340
Type	4 cycle, turbocharged
Bore mm	170
Stroke mm	170
Displacement litre	23.2
Cylinder block	6 cylinder
Battery charging alternator	35 amps
Starting voltage	24-volt
Fuel system	Cummins direct injection HPI
Fuel filter	Spin-on fuel filters with water separator
Lube oil filter type(s)	Spin-on full flow filter
Lube oil capacity (l)	103
Flywheel dimensions	SAE 0

Coolpac Performance Data

Cooling system design	Air-air charge cooled
Coolant ratio	50% ethylene glycol; 50% water
Coolant capacity (l)	110
Limiting ambient temp.** (°C)	50.9 (50Hz); 55.0 (60Hz)
Fan power (kWm)	14.4 (50Hz); 24.3 (60Hz)
Cooling system air flow (m³/s)**	13.5 (50Hz); 16.6 (60Hz)
Air cleaner type	Dry replaceable element with restriction indicator

** @ 13 mm H₂O

Fuel Consumption 1500 (50 Hz)

%	kWm	BHP	L/hr	US Gal./hr
Standby Power				
100	768	1030	178	46.9
Prime Power				
100	701	940	161	42.5
75	526	705	121	32.0
50	351	470	85	22.4
25	175	235	46	12.2
Continuous Power				
100	537	720	125	33.1

Fuel Consumption 1800 (60 Hz)

%	kWm	BHP	L/hr	US Gal./hr
Standby Power				
100	895	1200	212	56.1
Prime Power				
100	809	1085	189	49.8
75	607	814	139	36.7
50	405	543	97	25.7
25	202	271	56	14.7
Continuous Power				
100	653	875	149	39.4

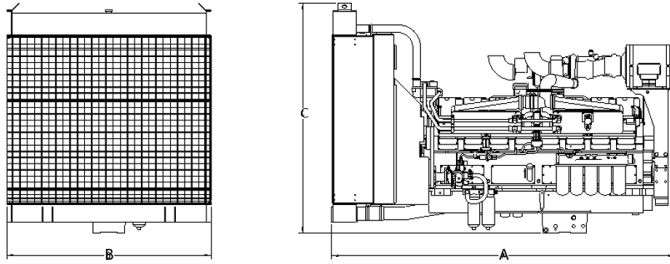

*Drawing for illustration purposes only.

Weights and Dimensions

Length mm	Width mm	Height mm	Weight (dry) kg
2976	1656	1964	3245

Ratings Definitions

Emergency Standby Power (ESP):	Limited-Time Running Power (LTP):	Prime Power (PRP):	Base Load (Continuous) Power (COP):
Applicable for supplying power to varying electrical load for the duration of power interruption of a reliable utility source. Emergency Standby Power (ESP) is in accordance with ISO 8528. Fuel Stop power in accordance with ISO 3046, AS 2789, DIN 6271 and BS 5514.	Applicable for supplying power to a constant electrical load for limited hours. Limited-Time Running Power (LTP) is in accordance with ISO 8528.	Applicable for supplying power to varying electrical load for unlimited hours. Prime Power (PRP) is in accordance with ISO 8528. Ten percent overload capability is available in accordance with ISO 3046, AS 2789, DIN 6271 and BS 5514.	Applicable for supplying power continuously to a constant electrical load for unlimited hours. Continuous Power (COP) in accordance with ISO 8528, ISO 3046, AS 2789, DIN6271 and BS 5514.

For more information contact your local Cummins distributor or visit power.cummins.com

Our energy working for you.™

BAV
Science and Industry Group
www.bav-co.com
+98 (21) 22407575

