

QSK78-G9

Emissions Compliance:
EPA Tier 1 @ 50 Hz

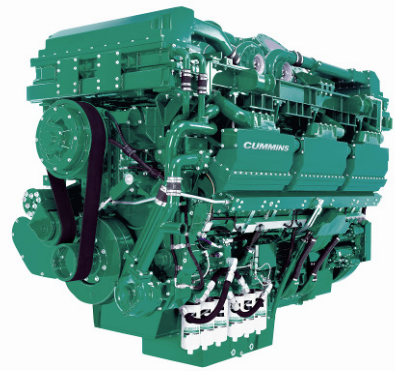

> Specification sheet



Our energy working for you.™

Description

The QSK78 is a V 18 cylinder engine with a 78 litre displacement. This Quantum series utilizes sophisticated electronics and premium engineering to provide outstanding performance levels, reliability and versatility for Standby, Prime and Continuous Power applications



This engine has been built to comply with CE certification.



This engine has been designed in facilities certified to ISO9001 and manufactured in facilities certified to ISO9001 or ISO9002.

Features

The new 4-turbo design architecture QSK78 uses the Cummins High Pressure Injection (HPI) PT full authority electronic fuel system. The HPI PT fuel system is managed by a G-Drive Governor Control System (GCS) controller, which is provided for off-engine mounting in the genset control panel. The Quantum Control has a specific fuel system board to interface with the HPI-PT fuel system and provides an Engine Protection package giving greater customer flexibility and cost effective alternatives in the control design and the benefits of Full Authority electronic control.

CTT (Cummins Turbo Technologies) HX82/HX83 turbo-charging utilizes exhaust energy with greater efficiency for improved emissions and fuel consumption.

Low Temperature After-cooling - Two-pump Two-loop (2P2L)

Ferrous Cast Ductile Iron (FCD) Pistons - High strength design delivers superior durability.

G-Drive Integrated Design - Each component has been specifically developed and rigorously tested for G-Drive products, ensuring high performance, durability and reliability.

Service and Support - G-Drive products are backed by an uncompromising level of technical support and after sales service, delivered through a world class service network.

1500 rpm (50 Hz Ratings)

Gross Engine Output			Net Engine Output			Typical Generator Set Output		
Standby	Prime	Base	Standby	Prime	Base	Standby (ESP)	Prime (PRP)	Base (COP)

Our energy working for you.™

www.cumminsgdrive.com

©2009 | Cummins G-Drive Engines | Specifications Subject to Change Without Notice | Cummins is a registered trademark of Cummins Inc. (05/09) (GDSS1xxx)

BAV
Science and Industry Group
www.bav-co.com
+98 (21) 22407575



kWm/BHP			kWm/BHP			kWe	kVA	kWe	kVA	kWe	kVA
2539/3404	2304/3088	2072/2777	2479/3324	2269/3043	2037/2732	2400	3000	2200	2750	1956	2444

Our energy working for you.™

www.cumminsgdrive.com

©2009 | Cummins G-Drive Engines | Specifications Subject to Change Without Notice | Cummins is a registered trademark of Cummins Inc. (05/09) (GDSS1xxx)

BAV
 Science and Industry Group
www.bav-co.com
 +98 (21) 22407575



General Engine Data

Type	4 cycle, Turbocharged, After-cooled
Bore mm	170
Stroke mm	190
Displacement Litre	77.6
Cylinder Block	Cast iron, 18 cylinder
Battery Charging Alternator	55A
Starting Voltage	24V
Fuel System	Direct injection Cummins HPI
Fuel Filter	Spin on fuel filters with water separator
Lube Oil Filter Type(s)	Spin on full flow filter
Lube Oil Capacity (l)	465
Flywheel Dimensions	SAE 00

Coolpac Performance Data

Cooling System Design	2 pump - 2 loop
Coolant Ratio	50% ethylene glycol; 50% water
Coolant Capacity (l)	Engine only – not applicable
Limiting Ambient Temp.**	
Fan Power	
Cooling System Air Flow (m ³ /s)**	
Air Cleaner Type	Dry replaceable element with restriction indicator

** @ 13 mm H₂O

Weight & Dimensions

Length	Width	Height	Weight (dry)
mm	mm	mm	kg
3062	1570	2031	9180

Fuel Consumption 1500 (50 Hz)

%	kWm	BHP	L/ph	US gal/ph
Standby Power				
100	2539	3404	569	150.3
Prime Power				
100	2304	3088	528	139.4
75	1728	2316	406	107.1
50	1152	1544	291	76.7
25	576	772	158	41.8
Continuous Power				
100	2072	2777	476	125.7

Cummins G-Drive Engines

Asia Pacific

10 Toh Guan Road
#07-01
TT International Tradepark
Singapore 608838
Phone 65 6417 2388
Fax 65 6417 2399

Europe, CIS, Middle

East and Africa
Manston Park Columbus Ave
Manston Ramsgate
Kent CT12 5BF, UK
Phone 44 1843 255000
Fax 44 1843 255902

Latin America

Rua Jati, 310, Cumbica
Guarulhos, SP 07180-900
Brazil
Phone 55 11 2186 4552
Fax 55 11 2186 4729

Mexico

Cummins S. de R.L. de C.V.
Eje 122 No. 200 Zona Industrial
San Luis Potosi, S.L.P. 78090
Mexico
Phone 52 444 870 6700
Fax 52 444 870 6811

North America

1400 73rd Avenue N.E.
Minneapolis, MN 55432
USA
Phone 1 763 574 5000
USA Toll-free 1 877 769 7669
Fax 1 763 574 5298

Ratings Definitions

Emergency Standby Power (ESP):

Applicable for supplying power to varying electrical load for the duration of power interruption of a reliable utility source. Emergency Standby Power (ESP) is in accordance with ISO 8528. Fuel Stop power in accordance with ISO 3046, AS 2789, DIN 6271 and BS 5514.

Limited-Time Running Power (LTP):

Applicable for supplying power to a constant electrical load for limited hours. Limited-Time Running Power (LTP) is in accordance with ISO 8528.

Prime Power (PRP):

Applicable for supplying power to varying electrical load for unlimited hours. Prime Power (PRP) is in accordance with ISO 8528. Ten percent overload capability is available in accordance with ISO 3046, AS 2789, DIN 6271 and BS 5514.

Base Load (Continuous) Power (COP):

Applicable for supplying power continuously to a constant electrical load for unlimited hours. Continuous Power (COP) in accordance with ISO 8528, ISO 3046, AS 2789, DIN6271 and BS 5514.

Our energy working for you.™

www.cumminsgdrive.com

©2009 | Cummins G-Drive Engines | Specifications Subject to Change Without Notice | Cummins is a registered trademark of Cummins Inc. (05/09) (GDSS1xxx)

BAV
Science and Industry Group
www.bav-co.com
+98 (21) 22407575



STAMFORD® | AvK®

LV 804 T WDG 13 - Technical Data Sheet

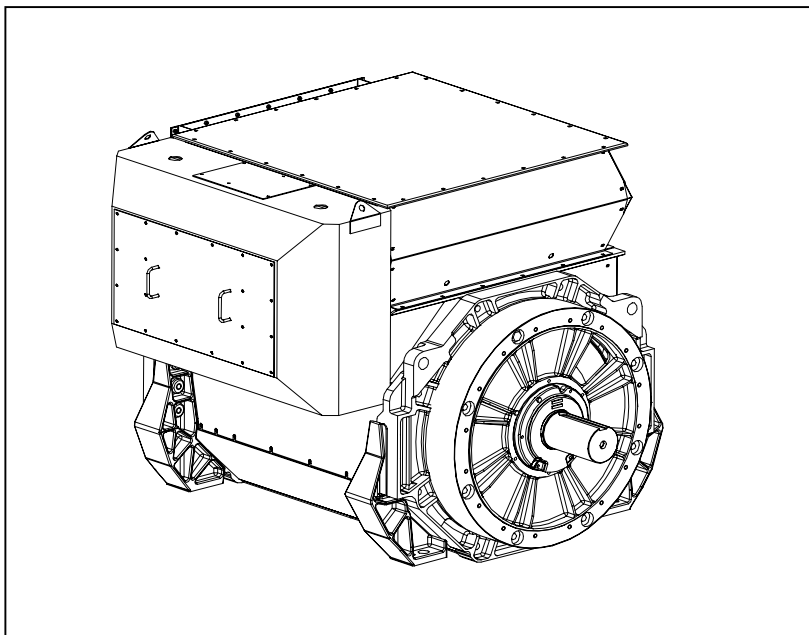

FRAME LV 804 T

SPECIFICATIONS & OPTIONS

STAMFORD | AvK

STANDARDS

Cummins Generator Technologies industrial generators meet the requirements of BS EN 60034 and the relevant sections of other national and international standards such as BS5000, VDE 0530, NEMA MG1-32, IEC60034, CSA C22.2-100, AS1359.

Other standards and certifications can be considered on request.

DESCRIPTION

The STAMFORD PI range of synchronous ac generators are brushless with a rotating field. They are separately excited by the STAMFORD Permanent Magnet Generator (PMG). This is a shaft mounted, high frequency, pilot exciter which provides a constant supply of clean power via the Automatic Voltage Regulator (AVR) to the main exciter. The main exciter output is fed to the main rotor, through a full wave bridge rectifier, protected by surge suppression.

VOLTAGE REGULATORS

The P range generators complete with a PMG are available with one AVR. The AVR has soft start voltage build up and built in protection against sustained over-excitation, which will de-excite the generator after a minimum of 8 seconds.

Underspeed protection (UFRO) is also provided on both AVRs. The UFRO will reduce the generator output voltage proportional to the speed of the generator below a pre-settable level.

The **MA330 AVR** is 3 phase rms sensed with a voltage regulation of 0.5% rms (see the note on regulation). The UFRO circuit has adjustable slope and dwell for controlled recovery from step loads. An over voltage protection circuit will shutdown the output device of the AVR, it can also trip an optional excitation circuit breaker if required. As an option, short circuit current limiting is available with the addition of current transformers.

The MA330 AVR needs a generator mounted current transformer to provide quadrature droop characteristics for load sharing during parallel operation.

Provision is also made for the connection of the STAMFORD power factor controller, for embedded applications, and a remote voltage trimmer.

WINDINGS & ELECTRICAL PERFORMANCE

All generator stators are wound to 2/3 pitch. This eliminates triplen (3rd, 9th, 15th ...) harmonics on the voltage waveform and is found to be the optimum design for trouble-free supply of non-linear loads. The 2/3 pitch design avoids excessive neutral currents sometimes seen with higher winding pitches. A fully connected damper winding reduces oscillations during paralleling. This winding, with the 2/3 pitch and carefully selected pole arc tooth designs, ensures very low levels of voltage waveform distortion.

TERMINALS & TERMINAL BOX

Standard generators feature a main stator with 6 ends brought out to the terminals, which are mounted on the frame at the non-drive end of the generator. A sheet steel terminal box contains the AVR and provides ample space for the customers' wiring and gland arrangements. It has removable panels for easy access.

SHAFT & KEYS

All generator rotors are dynamically balanced to better than BS6861:Part 1 Grade 2.5 for minimum vibration in operation. Two bearing generators are balanced with a half key.

INSULATION/IMPREGNATION

The insulation system is class 'H'.

All wound components are impregnated with materials and processes designed specifically to provide the high build required for static windings and the high mechanical strength required for rotating components.

QUALITY ASSURANCE

Generators are manufactured using production procedures having a quality assurance level to BS EN ISO 9001.

NOTE ON REGULATION

The stated voltage regulation may not be maintained in the presence of certain radio transmitted signals. Any change in performance will fall within the limits of Criteria 'B' of EN 61000-6-2:2001. At no time will the steady-state voltage regulation exceed 2%.

NB Continuous development of our products entitles us to change specification details without notice, therefore they must not be regarded as binding.

Front cover drawing is typical of the product range.

FRAME LV 804 T WINDING 13

RATINGS	REFER TO SALES AND SERVICE BRIEFING
MAXIMUM ALTITUDE	1000 METRES ABOVE SEA LEVEL
MAXIMUM AMBIENT TEMPERATURE	40° C
CONTROL SYSTEM SERIES 3	SEPARATELY EXCITED BY P.M.G.
A.V.R.	FULL WAVE RECTIFIED
VOLTAGE REGULATION	± 0.5% WITH 4% ENGINE GOVERNING
SUSTAINED SHORT CIRCUIT	REFER TO SHORT CIRCUIT DECREMENT CURVES OF THIS SECTION
INSULATION SYSTEM	CLASS H
PROTECTION	IP23 STANDARD
RATED POWER FACTOR	0.8
STATOR WINDING	DOUBLE LAYER LAP
WINDING PITCH	2/3
WINDING LEADS	6
R.F.I. SUPPRESSION	BS EN 50081/2-1/2 VDE 0875G VDE 0875N For other standards apply to the factory
WAVEFORM DISTORTION	NO LOAD < 1.5% NON-DISTORTING BALANCED LINEAR LOAD < 3.0%
MAXIMUM OVERSPEED	2250 Rev/Min
BEARING DRIVE END	ISO 6232 C3
BEARING NON DRIVE END	ISO 6324 C3
EFFICIENCY	REFER TO EFFICIENCY CURVES OF THIS SECTION
FREQUENCY	60Hz
TELEPHONE INTERFERENCE	TIF < 50
COOLING AIR	3.7 m ³ /sec
VOLTAGE STAR (Y)	380
KVA BASE RATING FOR REACTANCE VALUES	3400
Xd DIRECT AXIS SYNCHRONOUS	2.900
X'd DIRECT AXIS TRANSIENT	0.214
X''d DIRECT AXIS SUB-TRANSIENT	0.158
Xq QUADRATURE AXIS REACTANCE	1.950
X''q QUAD. AXIS SUB-TRANSIENT	0.293
Xl LEAKAGE REACTANCE	0.094
X2 NEGATIVE PHASE SEQUENCE	0.226
X0 ZERO PHASE SEQUENCE	0.029
REACTANCES ARE SATURATED	VALUES ARE PER UNIT AT RATING AND VOLTAGE INDICATED
T'd TRANSIENT TIME CONSTANT	0.190
T''d SUB-TRANSIENT TIME CONSTANT	0.015
T'do O.C. FIELD TIME CONSTANT	4.300
Ta ARMATURE TIME CONSTANT	0.075
SHORT CIRCUIT RATIO	1/Xd
STATOR WINDING RESISTANCE (L-N)	0.000314
ROTOR WINDING RESISTANCE	1.500
EXCITER STATOR FIELD RESISTANCE	17.50
EXCITER ROTOR RESISTANCE (L-L)	0.076
PMG STATOR RESISTANCE (L-L)	3.800
	RESISTANCE VALUES ARE IN OHMS AT 20° C
NO LOAD EXCITATION VOLTAGE	15.0
FULL LOAD EXCITATION VOLTAGE	63.0

Continuous development of our products entitles us to change specification details without notice, therefore they must not be regarded as binding.

THREE PHASE EFFICIENCY CURVES

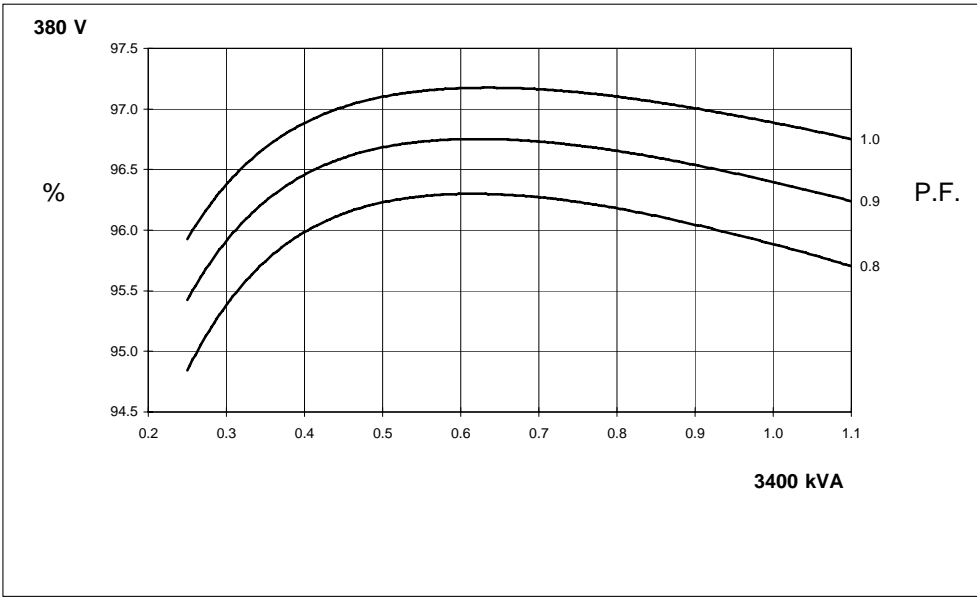

FULL WAVE RECTIFIED AVR
 LOCKED ROTOR MOTOR STARTING CURVE

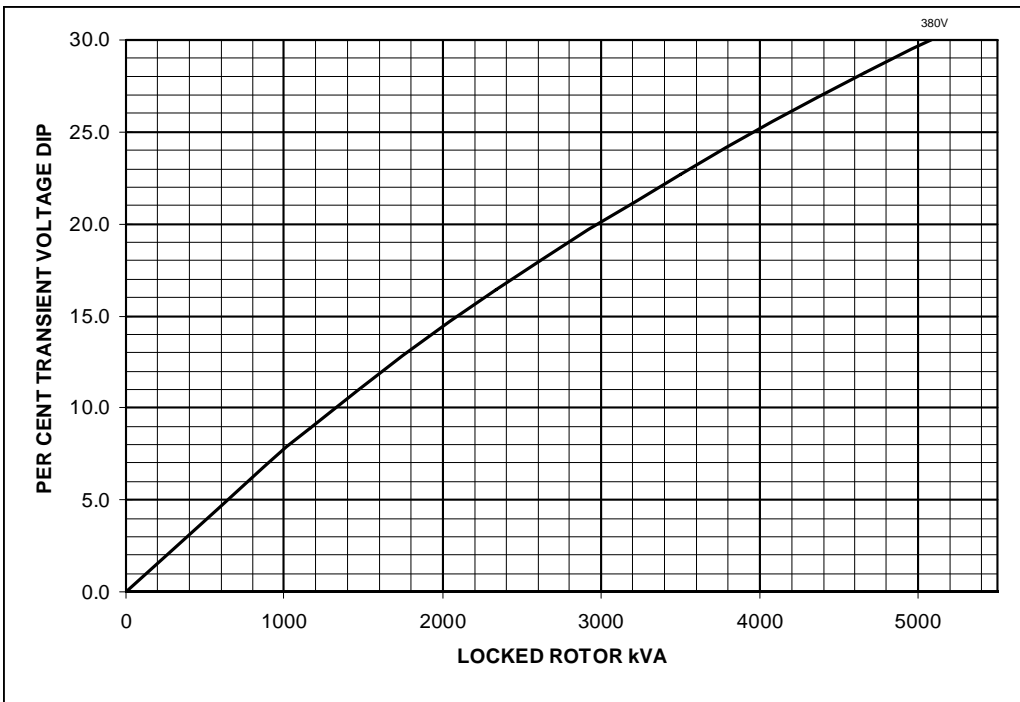

FRAME LV 804 T WDG 13 60Hz

Three Phase Short Circuit Decrement Curve
 No- Load Excitation at Rated Speed

Based on series star (wye) connection

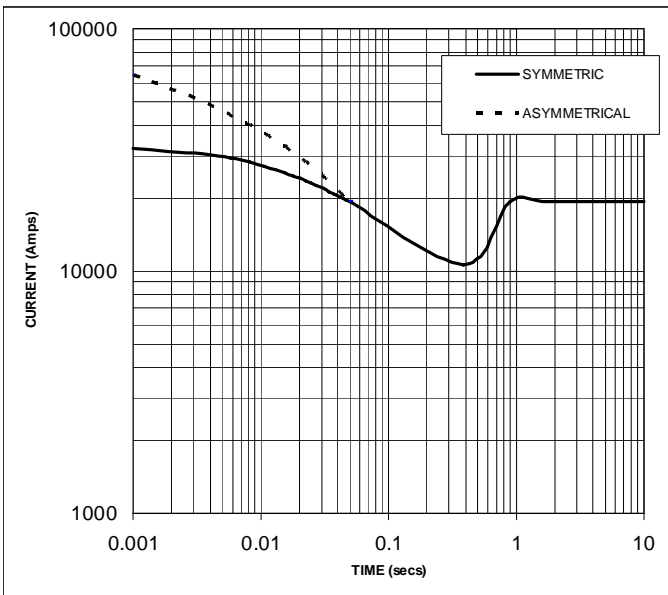

NOTE 1
 THE FOLLOWING MULTIPLICATION FACTORS SHOULD BE USED TO ADJUST THE VALUES FROM CURVES BETWEEN THE 0.001 SECONDS AND THE MINIMUM CURRENT POINT IN RESPECT OF NOMINAL OPERATING VOLTAGE

VOLTAGE	FACTOR
380V	X 1.00

THE SUSTAINED CURRENT VALUE IS CONSTANT IRRESPECTIVE OF VOLTAGE LEVEL

NOTE 2
 THE FOLLOWING MULTIPLICATION FACTORS SHOULD BE USED TO CONVERT THE VALUES CALCULATED IN ACCORDANCE WITH NOTE 1 TO THOSE APPLICABLE TO THE VARIOUS TYPES OF SHORT CIRCUIT

	3 PHASE	2 PHASE L-L	1 PHASE L-N
INSTANTANEOUS	X 1.0	X 0.87	X 1.30
MINIMUM	X 1.0	X 1.80	X 3.20
SUSTAINED	X 1.0	X 1.50	X 2.50
MAX SUSTAINED DURATION	10 SEC	5 SEC	2 SEC

ALL OTHER TIMES ARE UNCHANGED

SUSTAINED SHORT CIRCUIT = 19372 Amps

FRAME LV 804 T
WINDING 13 0.8 Power Factor



RATINGS

Class - Temp Rise		Cont. F - 105/40°C	Cont. H - 125/40°C	Standby - 150/40°C	Standby - 163/27°C
50Hz	Star (V)	N/A	N/A	N/A	N/A
	kVA	N/A	N/A	N/A	N/A
	kW	N/A	N/A	N/A	N/A
	Efficiency (%)	N/A	N/A	N/A	N/A
	kW Input	N/A	N/A	N/A	N/A
60Hz	Star (V)	380	380	380	380
	kVA	3130	3400	3630	3740
	kW	2504	2720	2904	2992
	Efficiency (%)	96.0	95.9	95.8	95.7
	kW Input	2609	2837	3033	3126

TYPICAL DIMENSIONS - Further arrangements available - please refer to factory

P80 R/S/T CORES

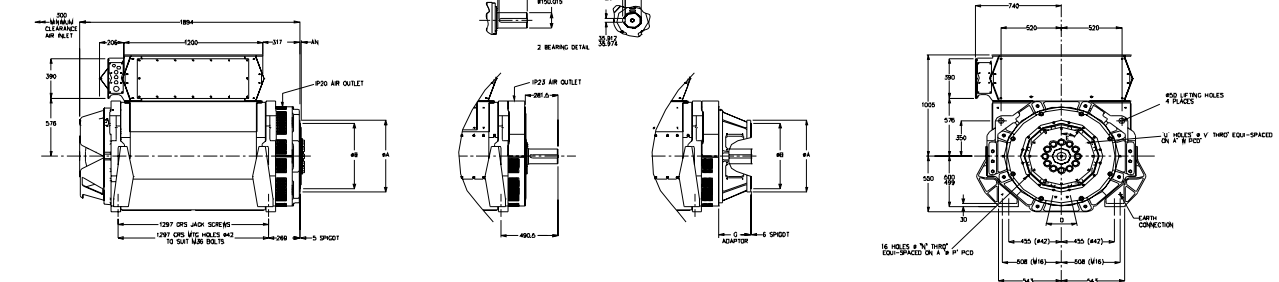

P80 R/S/T CORES 1-BRG ADAPTORS					
SAE	A	B	N	P	D
SAE 0	711	647.7	14	679.5	22.5"
SAE 00	883	787.4	14	851.0	22.5"

P80 R/S/T/W/X CORES 1-BRG COUPLING DISC						
SAE	AN	C	U	Y	W	E
1B	15.9	571.4	12	16.7	543.0	30"
21	0	673.0	12	16.7	641.3	30"
24	0	733.3	12	20.7	692.0	30"

P80 R/S/T/W/X CORES 2-BRG ADAPTORS		
SAE	G	
P80 R/S/T	0	271.5
P80 R/S/T	00	271.5
P80 W/X	0	271.5
P80 W/X	00	329.0

P80 R/S/T/W/X CORES 2-BRG ADAPTORS					
SAE	A	B	N	P	D
SAE 0	711	647.7	14	679.5	22.5"
SAE 00	883	787.4	14	851.0	22.5"

P80 W/X CORES

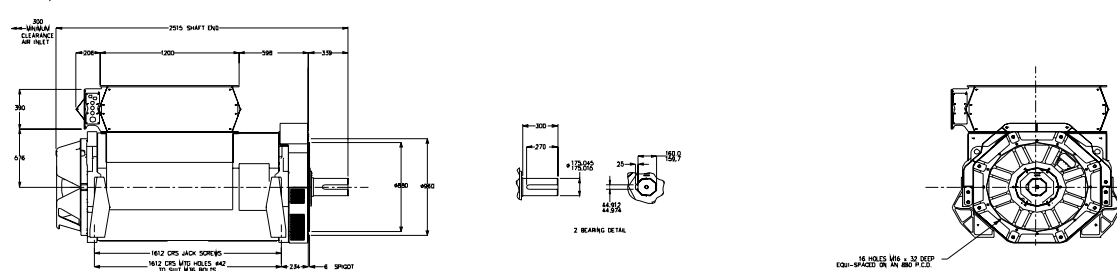

Barnack Road • Stamford • Lincolnshire • PE9 2NB
Tel: 00 44 (0)1780 484000 • Fax: 00 44 (0)1780 484100