

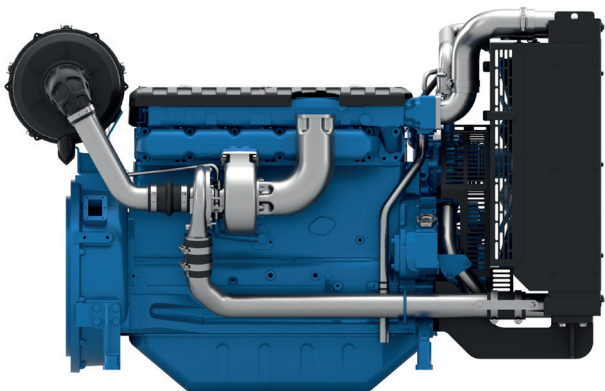

# 6M11

PowerKit ESP/PRP/COP Diesel Engine

**BAV**  
Science and Industry Group  
[www.bav-co.com](http://www.bav-co.com)  
+98 (21) 22407575



Bore & Stroke (mm)	105 x 130
Displacement (L)	6.75
N° of Cylinders	6
Cylinders Arrangement	In line
Fuel System	Mechanical
Governor (Gov.)	Electronic
Aspiration (Asp.)	Turbocharged & air-to-air cooled

**Customer benefits**

Warranty terms – 2 yrs unlimited PRP, 4 yrs/800h ESP  
50°C Cooling package standard with low derating  
Low fuel consumption across the range  
Extended mean time between overhauls (MTBO)

ESP/ PRP									
Diesel Engine Models	Gross Engine Output		Typical Generator Output				RPM	Asp.	Gov.
	ESP	PRP	ESP		PRP				
	kW <sub>m</sub>		kWe	kVA	kWe	kVA			
6M11G2D0/S	132	120	116	145	104	130	1500	T/A-A	ELEC
6M11G150/5	140	128	120	150	108	135	1500	T/A-A	ELEC
6M11G4D0/S	152	138	132	165	120	150	1500	T/A-A	ELEC
6M11G110/6	132	120	110	138	100	1250	1800	T/A-A	ELEC
6M11G2D0/S	152	138	132	165	120	150	1800	T/A-A	ELEC
6M11G135/6	158	144	135	170	120	150	1800	T/A-A	ELEC
6M11G4D0/S	180	164	160	200	145	181	1800	T/A-A	ELEC

\* Please note that models ending with S are switchable 50/60 Hz engines

COP									
COP Diesel Engine Models	Gross Engine Output		Typical Generator Output				RPM	Asp.	Gov.
	COP	PRP	COP		PRP				
	kW <sub>m</sub>		kWe	kVA	kWe	kVA			
6M11G2D0/5	117	138	100	125	120	150	1500	T/A-A	ELEC
6M11G2D0/6	132	144	112	140	120	150	1800	T/A-A	ELEC

## Standard Equipment

Engine and block	Cast iron gantry type structure block One-piece forged crankshaft Separate cast iron cylinder heads and wet liners Aluminum alloy pistons with oil cooling gallery
Cooling System	Radiator and hoses supplied directly mounted on the engine Thermostatically-controlled system with belt driven coolant pump and pusher fan
Lubrication system	Flat bottom large capacity oil pan Spin-on full-flow lube oil filter
Fuel system	P type fuel injection pump and injector for higher inject pressure Duplex fine filter for better efficiency
Air intake and exhaust system	Mid-position and below inlet turbocharger optimized for genset application Special rear mounted air filter with restriction indicator Exhaust manifold shield for heat isolating
Electrical System	12 Vdc electric starter motor and battery charging alternator for 1500 Rpm engines 24 Vdc electric starter motor and battery charging alternator for 1800 Rpm engines LOP + HWT sensors
Flywheel and housing	SAE 3 flywheel housing and 11.5" flywheel for 1500 Rpm SAE 1 flywheel housing and 14" flywheel for 1800 Rpm

## Dimensions and dry weight (mm/kg)

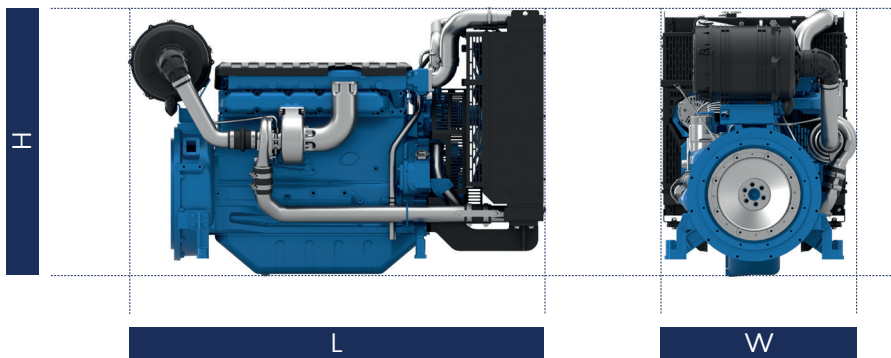

Diesel Engine	Speed RPM	Dimensions and dry weights including radiator			
		L mm	W mm	H mm	WEIGHT kg
6M11G150/5	1500	1712	806	1110	692
6M11G110/6	1800	1712	806	1110	692
6M11G135/6	1800	1712	806	1110	692
6M11G2D0/S	1500/1800	1712	806	1110	710
6M11G4D0/S	1500/1800	1712	806	1110	710

## Ratings definitions

### Emergency Standby Power (ESP)

Emergency Standby Power is the maximum power available for a varying load for the duration of a main power network failure. The average load factor over 24 hours of operation should not exceed 70% of the engine's ESP power rating. Typical operational hours of the engine is 200 hours per year, with a maximum usage of 500 hours per year. This includes an annual maximum of 25 hours per year at the ESP power rating. No overload capability is allowed. The engine is not to be used for sustained utility paralleling applications.

### Continuous Power (COP)

Continuous Power is the maximum power available for an unlimited period of use at a constant load factor. No overload capability is allowed.

### Prime Rated Power (PRP)

Prime Power is the maximum power available for unlimited hours of usage in a variable load application. The average load factor should not exceed 70% of the engine's PRP power rating during any 24 hour period. An overload capability of 10% is available, however, this is limited to 1 hour within every 12 hour period.

- 1) All ratings are based on operating conditions under ISO 8528-1, ISO 3046, DIN6271. Performance tolerance of  $\pm 5\%$ .
- 2) Test conditions: 100 kPa, 25°C air inlet temperature, relative humidity of 30%, with fuel density 0.84 kg/L.  
Derating may be required for conditions outside these; please contact the factory for details.

